



E-Class Cabriolet

Mercedes-Benz

Feel the warmth of the sun.

Dynamic even while at a standstill: the sporty arrow-shape of the front end extends from the radiator right across the entire bonnet.



You'll still get goose bumps

The prominent, rising side line blends into a distinctive, muscular tail end.



Journeys will seem shorter.

The E-Class Cabriolet elegantly leaves the slipstream behind and always leads the field – with agility,



And the summer much longer

outstanding technology and numerous assistance systems for safety and comfort.







The wind knows no limits.

The airflow is directed over the vehicle by a new draught-stop system of unique design.



So we showed it one

The open interior is therefore a calmer and quieter place to be – with noticeably more space even for four occupants.



Open-air comfort

Open-top driving at the highest level. Whether you're driving with the classic fabric roof up or down, the E-Class Cabriolet sets new standards in terms of comfort. Firstly because of an unprecedented, low level of noise. And secondly because the innovative AIRCAP technology, plus AIRSCARF and numerous assistance systems, ensures an enjoyable ride even on long journeys or when the weather is cool.

- Open-air driving for four: AIRCAP, an electrically operated air deflector module at the front of the roof frame, as well as a draught-stop between the rear head restraints, directs the airflow away from the entire interior (optional)
- Extremely quiet-running - with the roof open or closed
- A longer open-air driving season: when the roof is open, heated air from the AIRSCARF vents in the head restraints warms the shoulder and neck areas of the driver and front passenger (optional)
- Fully electric fabric roof: opening and closing in approx. 20 seconds possible at speeds up to 40 km/h, and from close range the roof can also be operated via radio remote control in the key
- Automatic belt feeders (also operable by means of button on centre console)

Design

A classic cabriolet on the one hand, exclusivity and a new sense of lightness on the other. An arrow-shaped front end with a prominent radiator grille and a centrally mounted Mercedes star communicates dynamism. The rising shoulder line with a pronounced "muscle" above the rear axle and a slightly raised tail end visually combines athleticism with elegance. Attributes that are also reflected beneath the classic fabric roof in the interior.

- Elegant cabriolet silhouette and exclusive exterior styling with a classic fabric roof
- Twin headlamp face with projection-beam headlamps
- Daytime driving lights combined with front fog lamps in twin circular design or LED design (optional)
- Mercedes-Benz star integrated into radiator grille with two louvres
- Striking tail end including diffuser and LED-design tail lights
- High-quality interior design with bucket-shaped single seats and integrated head restraints
- Exclusive ELEGANCE interior concept or sporty AVANTGARDE interior
- Dynamic AMG Sports package (optional)

E-Class Cabriolet. It's about airstream. Not mainstream.

Drive system

Efficiency and sportiness go hand in hand. In the interests of the environment and driving pleasure, the engines develop a higher output thanks to efficiency measures and have also been optimised with respect to emissions and fuel consumption. Perfectly coordinated transmissions ensure that the engine power is optimally transferred. The suspension variants available meet the needs of both comfort-oriented and more sports-oriented drivers.

- 3 diesel engines (4 and 6-cylinder variants)
- 4 petrol engines (4, 6 and 8-cylinder variants)
- 6-speed manual transmission (E 200 CGI, E 220 CDI and E 250 CDI), 5-speed automatic transmission (E 250 CGI, optional for E 200 CGI, E 220 CDI and E 250 CDI) or 7-speed automatic transmission (6 and 8-cylinder models)
- BlueEFFICIENCY technology for the 4 and 6-cylinder models
- AGILITY CONTROL package with selective damping system
- Dynamic Handling package with selectable Sport driving mode (standard for E 500, otherwise optional)

Safety

Numerous assistance systems ensure a pleasant and even safer journey in the E-Class Cabriolet. The anticipatory occupant protection system PRE-SAFE® is able to recognise critical driving situations as they develop, and initiate preventive measures. In addition, numerous assistance systems support the driver in these situations.

- Roll-over protection system, with roll-over bars – integrated into the rear head restraints – which can deploy within fractions of a second when needed
- The drowsiness detection system ATTENTION ASSIST recognises the typical signs of drowsiness and can alert the driver to an impending microsleep
- PRE-SAFE® system as standard
- ADAPTIVE BRAKE with Hill-Start Assist, brake drying and HOLD function
- Airbags, headbags and sidebags for the driver and front passenger, driver kneebag, sidebags in the rear (optional)
- DISTRONIC PLUS proximity control: helps the driver to stay at a safe distance from the vehicle ahead, even in stop-and-go traffic. If the system recognises the need, the associated PRE-SAFE® Brakes can initiate automatic partial and emergency braking (optional)
- Intelligent Light System with Adaptive Highbeam Assist (optional)

Standard equipment and interior concepts



The radiator grille with its two louvers and the light-alloy wheels in a 9-twin-spoke design emphasise the sporty elegance of the E-Class Cabriolet

The new E-Class Cabriolet already promises driving pleasure while it is at a standstill. It is shod with sporty light-alloy wheels as standard, and with the roof down it reveals an exclusive interior with high-grade materials such as aluminium trim and fabric/ARTICO man-made leather upholstery. Two design versions of the interior are available as standard. The ELEGANCE interior concept has a tone-in-tone colour scheme with light-coloured A and C-pillars and roof lining. The dashboard, steering wheel and selector lever are in a contrasting colour. In the AVANTGARDE interior concept, the A/C-pillars and the roof lining are in black. One of four contrasting colours can be combined with this for the optional leather upholstery. The door centre panels and rear side elements are also lined in the chosen colour. The fully electric fabric roof is available in three colours and boasts superb noise and heat-insulation properties.



The ELEGANCE interior concept: tone-in-tone upholstery with harmonious contrasting colours, light A and C-pillars and a black instrument cluster backplate



Black dominates the AVANTGARDE concept, as an option with one of four contrasting colours. The silver-coloured instrument cluster backplate accentuates the sporty look



First-row seats for passengers in the rear too: the individual seats with a stowage compartment in-between offer the utmost in comfort – shown here in the luxurious atmosphere of the ELEGANCE interior concept



The distinctive, more sporty AVANTGARDE interior concept is a visual treat in the rear too, thanks to an attractive colour scheme and absorbing contrasts

Optional extras



The AMG Sports package gives added impact to the sportiness of the E-Class with features such as the AMG front and rear aprons, side skirts, 18-inch AMG light-alloy wheels, an AMG sports steering wheel and a sports suspension with speed-sensitive sports steering

The range of optional extras offers a wealth of choice: AIRCAP and AIRSCARF turn almost any weather into open-top driving weather – for up to four occupants. The innovative AIRCAP system (an air deflector module at the front and a draught-stop between the rear head restraints) creates the best possible airflow conditions and directs it over the top of the vehicle. This reduces turbulence when the roof is open – especially in the rear – and considerably lowers the noise level. In addition, AIRSCARF bathes the head and shoulder areas of the driver and front passenger in warm air. Comfort and safety are enhanced by the DISTRONIC PLUS proximity control system, the Intelligent Light System with Adaptive High-beam Assist and the reversing camera. Brilliant sound comes courtesy of the the Harman Kardon® Logic 7® surround sound system. Even more sportiness is ensured by the Dynamic Handling package and the AMG Sports package.



Warm air flows from the vents of the AIRSCARF neck-level heating system to keep the head and shoulder areas of the front seat occupants warm. The vents are swivelling and therefore individually adjustable



The air deflector of the AIRCAP system directs the airflow over the interior in an arc. It extends at the touch of a button and retracts automatically



Speed Limit Assist (optional) identifies the signposted speed limit and displays it in the instrument cluster



Entertainment at your fingertips: the multimedia system COMAND APS helps the car to navigate and is equipped with a radio, CD/DVD player and Aux-in socket

NON-METALLIC PAINTS

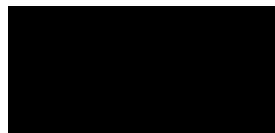

040 black



590 fire opal

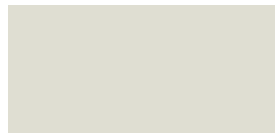

650 calcite white

METALLIC PAINTS¹



197 obsidian black



230 indigolite blue

METALLIC PAINTS¹



359 tanzanite blue



755 tenorite grey



775 iridium silver



792 palladium silver



798 sanidine beige



799 diamond white BRIGHT

SPECIAL PAINT FINISH¹

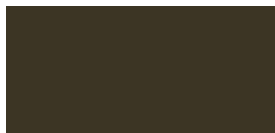

786 stannite grey

SOFT-TOP FABRIC

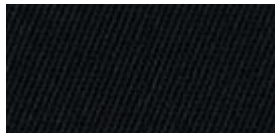

740 black



744 dark blue



745 dark beige

ELEGANCE colours



black



alpaca grey



almond beige

ELEGANCE trim (freely combinable in the interior concept)



739 brushed aluminium



731 burr walnut¹

ELEGANCE upholsteries



711^{2,3} fabric/ARTICO



201|801⁴ leather¹



208|808⁴ leather¹



205|805⁴ leather¹



H13 brown pine¹



H21 piano lacquer¹

AVANTGARDE colours



black | black



black | alpaca grey



black | almond beige

AVANTGARDE upholsteries



701^{2,3} fabric/ARTICO 101⁵ ARTICO



251 | 851⁴ leather¹



258 | 858⁴ leather¹



255 | 855⁴ leather¹

AVANTGARDE colours



black | natural beige



black | flamenco red

AVANTGARDE upholsteries



254 leather¹



257 leather¹

AVANTGARDE trim (freely combinable in the interior concept)



739 brushed aluminium



H21 piano lacquer¹



736 black ash¹

¹ Optional extra

² ARTICO man-made leather

³ Not in conjunction with AMG Sports package

⁴ Nappa leather

⁵ AMG Sports package in black ARTICO man-made leather as standard, available in leather and nappa leather as an optional extra

Dimensions

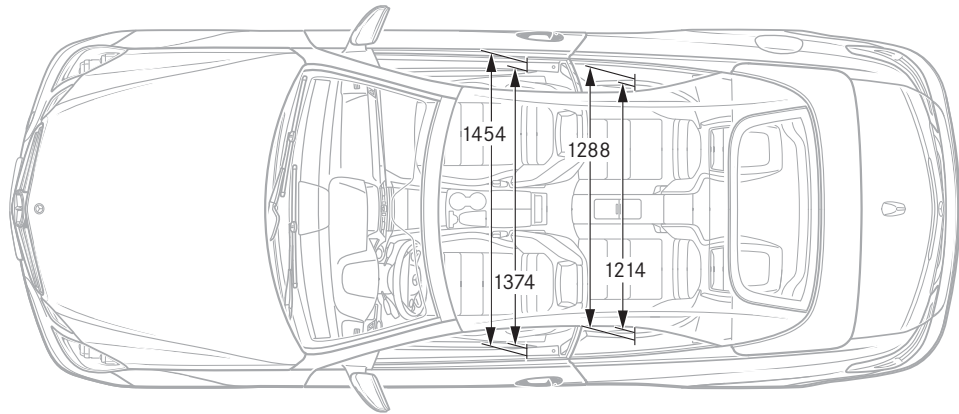
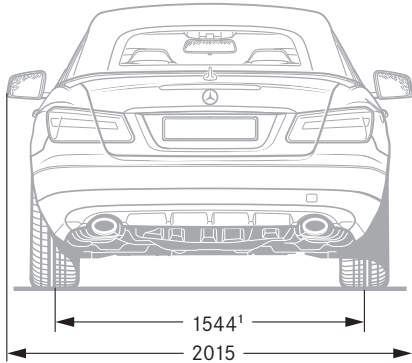
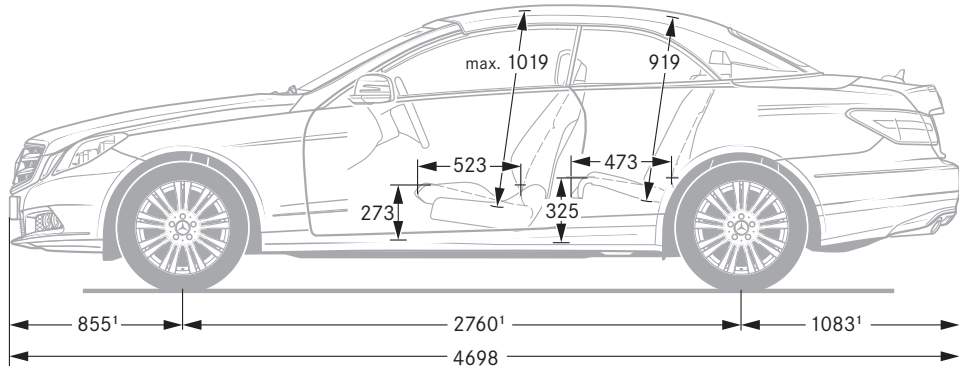
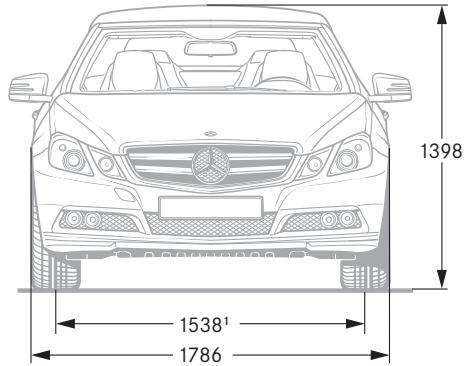

All measurements in millimetres. The dimensions shown are mean values and apply to standard specification, unladen vehicles. ¹ Carrying 3 occupants each weighing 68 kg

Technical data

	E 220 CDI	E 250 CDI	E 350 CDI
DIESEL ENGINES	BlueEFFICIENCY	BlueEFFICIENCY	BlueEFFICIENCY
Total displacement (cc)	2143	2143	2987
Rated output ¹ (kW at rpm) (manual transmission)	125/3000-4200 (125/3000-4200)	150/4200 (150/4200)	170/3800 (-)
Acceleration 0- 100 km/h (s) (manual transmission)	8.9 (8.8)	7.8 (7.8)	6.9 (-)
Top speed, approx. (km/h) (manual transmission)	230 (232)	243 (245)	250 ² (-)
Fuel consumption ³ (l/ 100 km)			
urban (manual transmission)	8.4-8.5 (6.9-7.0)	8.4-8.5 (7.3-7.4)	9.1 (-)
extra-urban (manual transmission)	4.8-5.0 (4.6-4.8)	4.8-5.0 (4.7-4.9)	5.9-6.1 (-)
combined (manual transmission)	6.2-6.3 (5.4-5.6)	6.2-6.3 (5.6-5.8)	7.0-7.2 (-)
CO ₂ emissions ³ (g/km), combined (manual transmission)	162- 165 (143- 148)	162- 165 (148- 153)	185- 189 (-)

	E 200 CGI	E 250 CGI	E 350 CGI	E 500
PETROL ENGINES	BlueEFFICIENCY	BlueEFFICIENCY	BlueEFFICIENCY	
Total displacement (cc)	1796	1796	3498	5461
Rated output ¹ (kW at rpm) (manual transmission)	135/5250 (135/5250)	150/5500 (-)	215/6400 (-)	285/6000 (-)
Acceleration 0- 100 km/h (s) (manual transmission)	8.6 (8.8)	7.8 (-)	6.8 (-)	5.3 (-)
Top speed, approx. (km/h) (manual transmission)	231 (236)	240 (-)	250 ² (-)	250 ² (-)
Fuel consumption ³ (l/ 100 km)				
urban (manual transmission)	11.0- 11.2 (10.1- 10.3)	11.0- 11.2 (-)	12.8- 12.9 (-)	15.9 (-)
extra-urban (manual transmission)	6.1-6.4 (5.8-6.1)	6.1-6.4 (-)	6.5-6.6 (-)	8.2 (-)
combined (manual transmission)	7.9-8.2 (7.4-7.6)	7.9-8.2 (-)	8.8-9.0 (-)	11.0 (-)
CO ₂ emissions ³ (g/km), combined (manual transmission)	185- 190 (172- 177)	185- 190 (-)	206-208 (-)	257 (-)

¹ The figures shown are obtained in accordance with the prescribed measuring process (Directive 80/1269/EEC in the currently applicable version) ² Electronically governed ³ The figures shown are obtained in accordance with the prescribed measuring process (Directive 80/1269/EEC in the currently applicable version). They are not based on an individual vehicle and do not constitute part of the product offer; they are provided solely for the purposes of comparison between different vehicle models
Further technical data are available at www.mercedes-benz.com

Take-back of end-of-life vehicles. Coming full circle. At the end of its long life, you can return your E-Class to us for environmentally friendly disposal in accordance with the EC End-Of-Life Vehicle Directive¹. But that day lies a long way off.

¹ Applies in accordance with national regulations to vehicles up to 3.5 tonnes gross weight. Mercedes-Benz passenger cars have met the statutory regulations governing the suitability of their design for reuse and recycling for a number of years. A network of vehicle take-back depots and dismantlers has been established which will process your vehicle in an environmentally compatible manner. The ways in which both vehicles and parts can be recovered are subject to ongoing development and improvement. Consequently, the E-Class will be able to comply with any future increases in the recycling quota within the stipulated time limits. For further information, please call 00800 1 777 7777.

Please note: changes may have been made to the product since this brochure went to press (23.10.2009). The manufacturer reserves the right to make changes to the design, form, colour and specification during the delivery period, provided these changes, while taking into account the interests of the vendor, can be deemed reasonable with respect to the purchaser. Where the vendor or the manufacturer uses symbols or numbers to describe an order or the subject of an order, no rights may be derived solely from these. The illustrations may show accessories and items of optional equipment which are not part of standard specification. Colours may differ slightly from those shown in the brochure, owing to the limitations of the printing process. This brochure has been compiled by Daimler AG of Germany and is distributed internationally. It provides a general indication of the range of models, features, optional extras and/or colours available in various countries. Some of the models, features, optional extras and/or colours shown may not be available in your country or may only be available in a different specification. Additionally some models, features, optional extras and/or colours may only be available in combination with others. For current and more specific information in relation to the range of models, features, optional extras and/or colours available in your country, and their pricing, please contact your nearest authorised Mercedes-Benz Passenger Car Dealer.
www.mercedes-benz.com